



Type: UFPD 06, UFPD 1.06 UFPD 10, UFPD 1.10

Liquid Pulsation Damper

for use with KNF Liquid Pumps
Corrosion-Resistant Materials

Model UFPD 10KPZ pulsation damper shown.

Description

The UFPD liquid pulsation damper was developed because of increased interest in low pulsation requirements. It reduces the inherent pressure waves created by an oscillating diaphragm pump. It also aids in the reduction of vibration in system hoses and pipes. With the correct selection of damper, a pressure fluctuation of less than 3 psi (200 mbar) can be achieved.

Selection Chart

For Pump Type	Use Damper Model
NF10	UFPD 06KPZ7
NF30	UFPD 06KPZ1
NF60	UFPD 06KPZ1
NF100	UFPD 06KPZ2
NF1.30	UFPD 1.06KPZ3
NF300	UFPD 10KPZ5
FM15	UFPD 1.10KPZ0
FM30	UFPD 1.10KPZ0
NF1.100	UFPD 1.10KPZ4
NF1.300	UFPD 1.10KPZ6
FM1.15	UFPD 1.10KPZ0
FM1.30	UFPD 1.10KPZ0

Application Data

The damper should be located as close to the pump as possible. For a flow rate that is different from the standard KNF pump performance curve, a different damper may be required. In addition, flow rate, pressure and stroke frequency all influence damper performance. Pump back pressure may increase by 7 to 30 psi. A different pump, suitable for higher pressures, may be necessary. It is available in PVDF/FFPM materials for corrosive service.

Dimensional

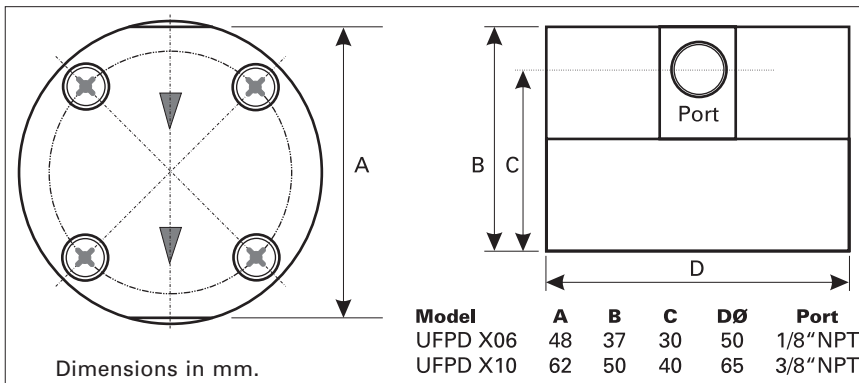

Environmental

Max. Ambient Temp. +80°C (176°F)
 Max. Medium Temp. +80°C (176°F)
 NPT Ports: Specify UFPD
 G Ports: Specify FPD

Available Wetted Materials:

UFPD_KPZ PP, EPDM
 UFPD_KTZ PP, FFPM
 UFPD_TTZ PVDF, FFPM

KNF NEUBERGER, INC.

Two Black Forest Road
 Trenton, NJ 08691-1810
 609/890-8600 • Fax: 609/890-8323
 pumps@knf.com • www.knf.com/usa.htm